

# FUSE PROTECTION OF TRANSFORMER POLE SUBSTATION IN POLAND

Józef Ossowicki<sup>(1)</sup>, Remigiusz Joeck<sup>(2)</sup>

Instytut Elektrotechniki Oddział w Gdańsku<sup>(1)</sup>, 80-557 Gdańsk, ul. Narwicka 1  
ENERGA SA<sup>(2)</sup>, 80-557 Gdańsk, ul. Marynarki Pol. 130, remigiusz.joeck@energa.pl

**Abstract:** The transformers protection in pole substations MV/LV 15/0,4 kV or 20/0,4 kV, is closely connected with the protection of complete substation. In Poland, on the MV side mainly expulsion fuses are used but on the LV side are used current limiting fuses with t-I characteristic gG or gF. It was proved that transformers rated up to 400 kVA could be effectively and inexpensively protected by fuses against results of overloads and short-circuits.

**Keywords:** protection, transformer pole substation, expulsion fuses, overload, short-circuits, t-I characteristic

## 1. Introduction

Correct protection of transformer pole substation MV/LV against overloads and short-circuits, has an essential influence on consumers supply continuity and safety of people or animals situated close to the substations. In Poland MV pole substations with typical rated voltage of 15/0,4 kV or 20/0,4 kV are mainly situated on the terrains of: agriculture, small industrial plants or other consumers. They are built as free-standing constructions with solutions depending on local conditions. Many years of domestic maintenance experiences proved [4] that the cheapest as well as effective transformer protection in these substations on the MV and LV side against results of overloads and short-circuits, are properly selected fuses [1, 3, 8, 10, 11]. In Poland for 40 years for protection of three-phase transformers rated up to 400 kVA on the 15 kV or 20 kV side, where prospective short-circuit current does not exceed 3,15 kA [4, 8, 19], were used domestic expulsion fuses (fig. 1A). For protection of larger transformers or in case of larger short-circuit currents there are used limiting fuses (fig. 1B).

Voltage, rated current and breaking capacity of a fuse are selected according to the basic rules, taking into consideration permissible transformer overloads.

The permissible operation overload is essential in the case of distribution transformers. It was accepted that distribution oil transformer overloads with current  $1,5 I_{nT}$  and  $1,3 I_{nT}$  should not last longer than adequately 2 and 10 h [5]. Due to the fact that the transformer has thermal time-constant larger than series connected conductors and apparatus, all circuit elements [5] should have the rated current larger than transformer e.g.  $I_n \geq 1,25 I_{nT}$ . This rule applies also secondary transformer circuit.

At the beginning of the 70-ties there was a tendency in Western Europe, especially in France to simplify transformer pole substation by eliminating protections on the MV side. Many fuses were removed what was explained that they operate due to not justified reasons. It was soon apparent that the fuses lack of was the reason of many transformers faults which were dangerous for surrounding. There were stated cases of oil leaks and even oil ignition which is an unacceptable ecological danger for the environment.

Considering different ways of transformer pole substation protection, the transformers faults statistics should be observed. Statistics from different countries could differ a lot, because they concern transformers produced, installed, protected and

supervised according to the rules of specific technical education. Polish observations of 6 000 distribution transformers from period 1990 – 1992, proved that every year 1% of them are damaged, c.a. 2/3 faults are internal short-circuit of HV windings, from these windings to core or oil tank, and also between HV winding and LV winding [5]. (Undoubtedly, the newest domestic transformers have several times lower fault rates). Similar German observation [1] of 600 000 oil distribution transformers, proved that average fault rate was ten times lower because every year 0,1% transformers were damaged. Despite a small fault amount in the latest years, due to the ecological requirements, there is an observed noticeable comeback to protection of transformer pole substations by fuses. It was proved by experimental testing [2] carried out on single-phase transformer substations models, rated 50 and 100 kVA. The testing aim was an explanation of MV fuses operation without reasons especially during atmospheric discharges. The good example could be the co-operation between French power engineers and SIBA company where the new fuse construction

was developed [20]. It enables easy fuse links replacement by hot stick from the ground level (without pole climbing).

On the contrary to West Europe experiences, in Poland almost for 10 years there is a tendency to eliminate MV fuses in pole substations which are rated lower than 400 kVA [6, 12]. It is a result of too many unjustified reasons of expulsion fuse operations, caused probably by information lack in catalogues how to select properly these fuses considering operation co-ordination with fuses on the LV side. For example in the catalogue [19] there are presented recommended expulsion fuse nominal currents for transformer protection on the rated voltage of 15 kV. The maximum nominal currents of fuses with gG characteristic which can be used on the 0,4 kV side there were not mentioned.

**2. Fuse selection in transformer pole substations**

In Poland are used three variants of transformer substation protection by fuses (fig. 1).

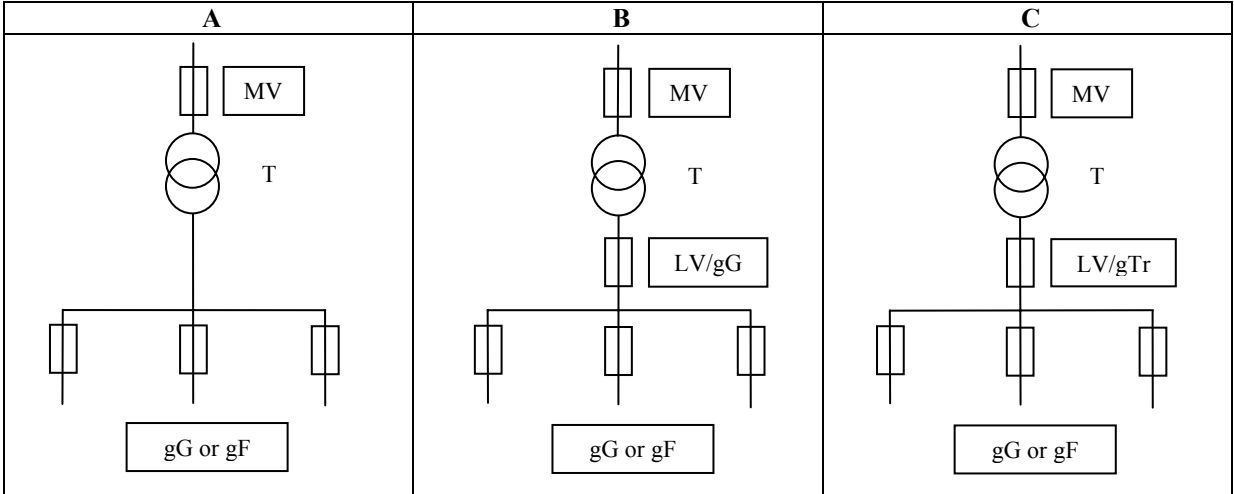

Fig. 1. Protection methods of transformer pole substations MV/LV

The protection method should be selected according to nominal transformer power and prospective short-circuit current on the MV side.

- **A** – On the MV side are used expulsion fuses when nominal transformer power is not larger than 400 kVA and prospective short-circuit current does not exceed 3,15 kA (unless the expulsion fuses producer proves that his fuses can be used for protection of transformers with larger nominal power or in network with larger prospective short-circuit current).
- **B** – On the MV side are used classic current limiting fuses when prospective short-circuit

current is larger than 3,15 kA or when nominal transformer power exceeds 400 kVA.

- **C** – Is used when nominal transformer power is larger than 630 kVA and does not exceed 1000 kVA.

Typical transformer pole substation (fig. 2) consists of a transformer (T) with nominal power not exceeding 250 kVA supplied from MV network usually through expulsion fuses (1), and surge arresters (not shown on the fig. 2).

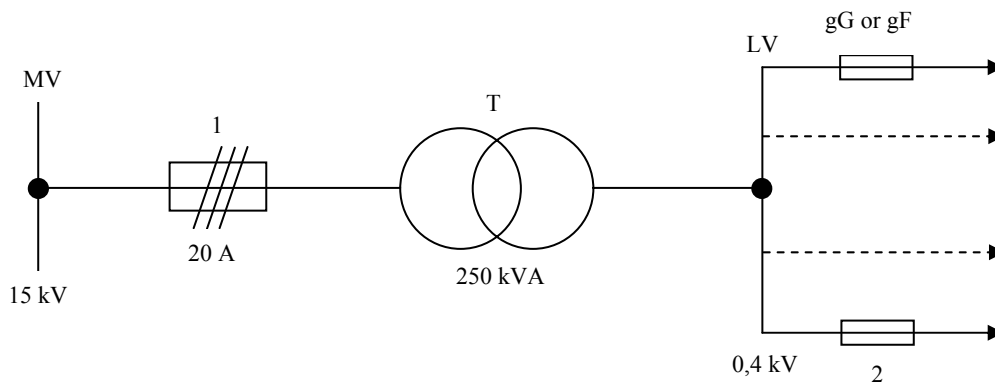

Fig. 2. Typical diagram of transformer pole substation ( overvoltage protection is not shown )

In the new products offered among other producers by ZRE Gdańsk [18] one of MV fuse base insulator is also a surge arrester. On the transformers secondary side, in the LV part, particular outgoing feeders are protected by fuses (2) with t-I characteristic gG or fast gF in case of rural network when shock prevention is required.

### 3. Protection on the MV side

The tasks of MV fuses in transformer pole substation are:

- protection of the substation part between fuses connections and transformer clamps against results of short-circuits,
- transformer protection against: oil tank fault, oil leak and possible its ignition due to the short-circuit inside transformer caused by e.g. insulation breakdown,
- cut-off of two and three-phase short-circuits when they appears on the secondary transformer side, on the substation part between bushings and fuse entrance clamps or fuse load switches on the particular outgoing feeders (fig. 2).

Fuses for transformers protection should have big enough operation current  $I_{f0,1}$  with prearcing time of

0,1 s regarding making current holding and selectivity with protections on the secondary side. Relative value (with reference to nominal current of fuse-link  $I_n$ ) should fulfil the condition (1) [16]

$$\frac{I_{f0,1}}{I_n} \geq 7 \cdot \left( \frac{I_n}{100} \right)^{0,25} \quad (1)$$

Fuses should have relatively small prearcing current  $I_{f10}$  in time 10 s due to detection of turn to turn short-circuit on the secondary transformer side and selectivity with preceding protections, so the condition (2) [16] should be fulfilled

$$\frac{I_{f10}}{I_n} \leq 6 \quad (2)$$

**MV fuses should be selected according to the following:**

- Their nominal short-circuit breaking capacity declared by producer should be not lower than prospective short-circuit current in the installation place.
- They should not operate during transformer switching on in any phase time. It is a convention [5, 8] that prearcing time at current  $12 I_{nT} \geq 0,1$  s; and at current  $25 I_{nT} \geq 0,01$ s. In their catalogues fuse producers usually describe type and values of fuse nominal currents which should be used for transformers protection.
- Their t-I characteristic in prearcing time (starting from overload to short-circuit in whole range) should run above t-I characteristic of LV fuse cut-off for the biggest nominal current of fuse situated in LV switchgear (fig. 3). Usually it is accepted that it is the close current to nominal transformer current  $I_{nT}$ .

- They should operate in a period shorter than 1 s, if two or three-phase short-circuit on the secondary transformer side in the substation part between bushings and LV fuses clamps appear (fig. 2);
- The maximum value of Joule integral  $I^2t$  of MV fuse cut-off should not exceed  $10^6 A^2s$ . This condition is caused by durability of transformer tank to bursting when internal short-circuit occurs in the transformer [10].

Requirements mentioned above are easily met in domestic expulsion fuses [4, 17, 19].

On the Fig. 3, continuous lines present prearcing t-I characteristics of expulsion fuses for rated voltage of 15 kV (have been produced in Poland for many years). Dashed lines show the characteristics (calculated to the 15 kV side) of maximum fuse disconnection time (characteristic gG) permitted by Polish Standard [14]. Fuses from many producers are in use in Poland. Their t-I characteristics sometimes differ a lot but all of them should be placed in required band shown in Polish Standard [14]. Due to their variety maximum characteristics of permissible disconnection times should be chosen in the selectivity analysis. The greatest approach between these characteristics, occurs when short circuit current on the 0,4 kV side calculated to the 15 kV side is ca.  $2,5I_n$  of expulsion fuse.

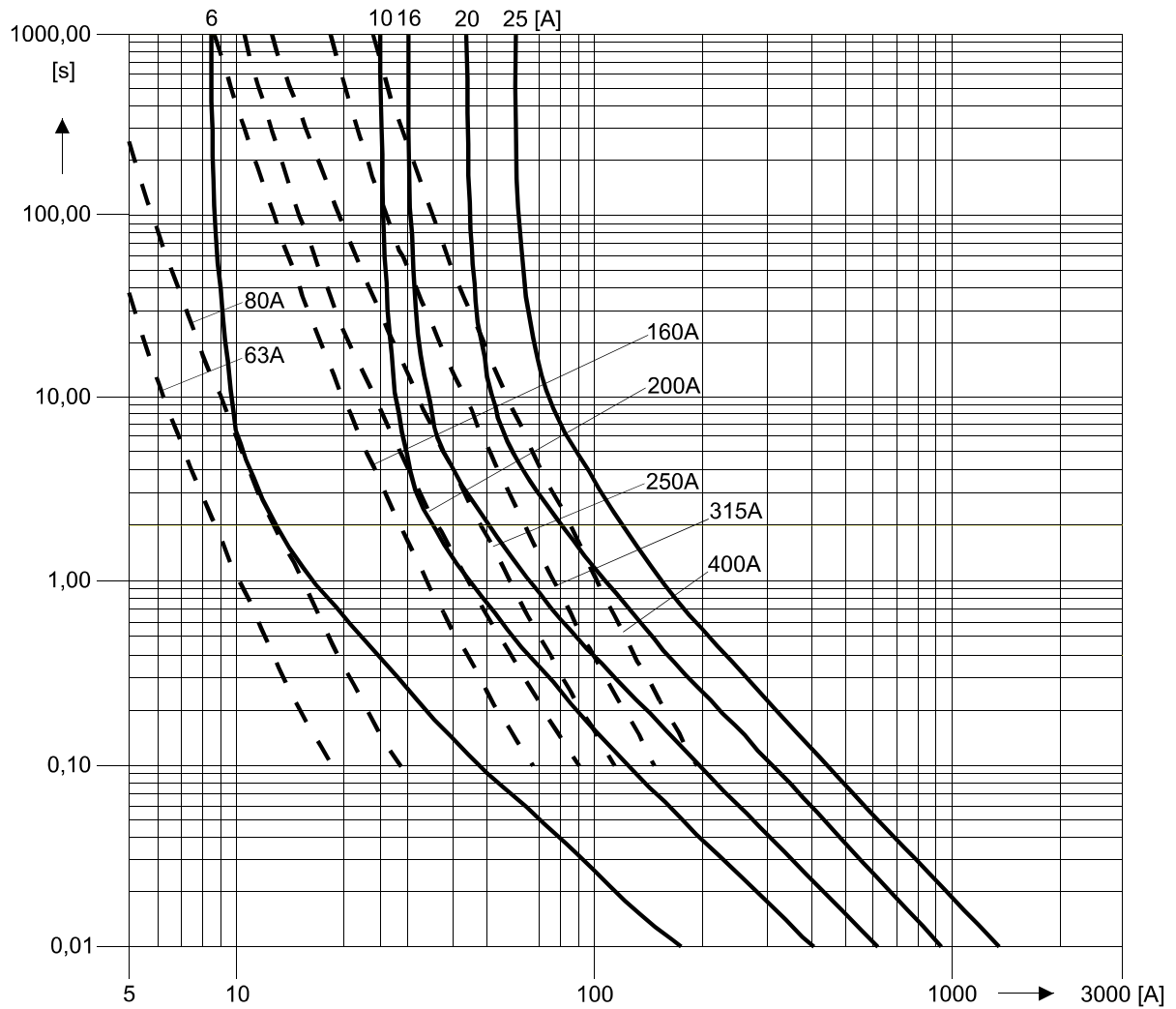

Fig. 3. Example of t-I characteristics of: prearcing domestic expulsion 15 kV fuses (continuous lines); gG fuse disconnection calculated to the 15 kV side (dashed lines). Explanations in the text ...

In Table 1 it is shown an example of properly selected domestic expulsion fuses which protect the transformers rated 63 ÷ 400 kVA. On the 0,4 kV side there are used fuses with gG characteristic.

Table 1. Example of fuse selection in transformer pole substations 15/0,4 kV

Transformer rated power [kVA]	Nominal voltage 15 kV		Nominal voltage 0,4 kV	
	Transformer rated current [A]	Fuse rated current [A]	Transformer rated current [A]	Fuse rated <sup>*)</sup> current [A]
63	2,43	6	91,0	63
100	3,85	10	144,5	125
160	6,20	16	231,0	200
250	9,60	20	361,0	315
400	15,40	25	578,0	400

\*) It is the largest rated current of gG fuse-link which assures selective fuse operations.

## 4. Protection on the LV side

- Fuse selection and protection method of transformer pole substation on the LV side depends mainly on nominal transformer power, less on fuse type or prospective short-circuit current on the MV side.
- To protect transformers rated up to 400 kVA against results of overloads and short-circuits, properly selected fuses on outgoing feeders in LV switchgear (fig. 1A) should be satisfied, because in opinion of experienced people there is a low probability of exceeding permissible transformer overloads by current  $1,3 I_{nT}$  during 10 h and current  $1,5 I_{nT}$  during 2 h.
- To protect transformers larger than 400 kVA should be used a protection on the entrance to the LV switchgear. For this purpose fuses with transformer characteristic gTr are the most suitable [17] (fig. 1C). Their advantages are that they enable full using of permissible transformer overload [9] and better limit short-circuit current than fuses with gG characteristic.

## 5. Conclusions

- Many years of maintenance experiences in West Europe concerning use of classic limiting fuses and Polish experiences in use MV expulsion fuses, point at that the cheapest and also most effective way of transformer protection and other parts of substation, against results of overload and short-circuit are properly selected fuses.
- For transformer protection on the MV side with nominal power not exceeding 400 kVA, when prospective short-circuit currents do not exceed 3,15 kA, domestic expulsion fuses are recommended [18].

- Transformers larger than 400 kVA should be protected by classic short-circuit current limiting fuses when prospective short-circuit current exceeds 3,15 kA on the MV side.
- The mistakes in maintenance can be avoided if expulsion fuse links are marked by transformer nominal power and not by nominal current, according to the standard DIN/VDE [17] for LV fuse links with gTr characteristic.
- The MV fuses task is to protect transformers against results of internal short-circuit (oil tank damage, oil leak and possible its ignition due to short-circuit occurred inside the transformer) and cut-off of two and three-phase short-circuit when it appears on the primary or secondary side in the substation part between transformer clamps and fuses.
- Due to the introduction of a new standard PN-IEC 60282-2 [14], some technical parameters of domestic expulsion fuses (especially for rated current of 6A) should be corrected and catalogues completed with necessary technical data, especially Joule integral  $I^2t$  in prearcing time and during cut-off is what is needed for designers and users for proper fuses application.

## 6. References

- [1] Hampel W. ; Hartmann E.; Karlscheur W.; Tenberge W.: „Schutz von Verteilungstransformatoren“, Elektrizitätswirtschaft, Jg. 91 (1992), Heft 25 z. 1660-1663
- [2] Hamel A.; Paquette M.; St-Jean G.: “Nuisance Fuse Operation on MV Transformers During Storms”, IEEE Transactions on Power Delivery, Vol. 5, No. 4, November 1990
- [3] Hartmann E.: „Verhalten und Schutz von Verteilungstransformatoren“, CIREN 89
- [4] Kacprzak B.; Hyrczak A.: “Service experience of new high-voltage expulsion fuses at rural outdoor networks”, CIREN 1989, s. 76-79
- [5] Lipski T.; Musiał E.: „Bezpieczniki topikowe i ich zastosowania”, Rozdz.8.4.

- Podręcznik przygotowany do druku
- [6] Michniewski R.: „Eksploatacja stacji transformatorowych 15/0,4 kV słupowych uproszczonych w ZE Toruń S.A.”, Biul. Infor. PTPiREE, nr 2/96
- [7] Ossowicki J.; Sibilski H.: „Zabezpieczenia rozdzielnic pierścieniowych średniego napięcia”, WE 2000, nr 9
- [8] Ossowicki J.: „Nowoczesne zabezpieczenia transformatorów rozdzielczych”, Przedsiębiorstwo ENERGO- EKO- TECH Poznań - Kierzk paźdz. 2000
- [9] Ossowicki J.: „Bezpieczniki topikowe o charakterystyce gTr w stacjach transformatorowych”, Biul. Infor. PTPiREE nr 3/2002
- [10] Planzlaff K.P., Schemmann B.: „Prüfung des Verhaltens bei inneren Fehlern im Transformatorenraum bei nicht begehbaren Ortsnetzstationen“, Elektrizitätswirtschaft, Jg. 89(1990) Heft 16/17
- [11] Popeck C.A., Lewis W.A. and Allen G. D.: “The Application of Current Limiting to Distribution Circuit Protection”, USA 1977
- [12] „STANDARDY TECHNICZNE OBOWIAZUJĄCE DLA URZĄDZEŃ SN i nN EKSPLOATOWANYCH W ENERDZE GDAŃSKIEJ KOMPANII ENERGETYCZNEJ”, S.A. Gdańsk styczeń 2002
- [13] PN-92/E-06110: „Bezpieczniki topikowe wysokiego napięcia. Bezpieczniki ograniczające prąd”
- [14] PN-HD 630.2.1. S5: 2003 (U) „Bezpieczniki topikowe niskonapięciowe. Część 2-1: Wymagania dodatkowe dotyczące bezpieczników przeznaczonych do wymiany przez osoby wykwalifikowane (przeznaczone głównie do stosowania w przemyśle). Sekcja od I do V: Przykłady typowych znormalizowanych bezpieczników”
- [15] PN-IEC 60282-2: „Bezpieczniki topikowe wysokonapięciowe. Bezpieczniki gazowydmuchowe”, listopad 1999
- [16] IEC Publ. 787: “Application guide for the selection of fuse-links of high voltage fuses for transformer circuit applications”, 1983
- [17] DIN/VDE 0636-201/A10 z października 1997.: „Niederspannungssicherungen (NH-System) Teil 2: Zusätzliche Anforderungen an Sicherungen zum Gebrauch durch Elektrofachkräfte bzw. elektrotechnisch unterwiesene Personen (Sicherungen überwiegend für den industriellen Gebrauch). Hauptabschnitte I bis V“
- [18] Katalog firmy ZRE Gdańsk: „Wysokonapięciowy zespół zabezpieczający typu WZZ”
- [19] Katalog firmy ZRE Gdańsk: „Wkładka bezpiecznikowa gazowydmuchowa napowietrzna typu WBGN”
- [20] Katalog firmy SIBA: „HH –Sicherungseinsätze HH 1- 03/00“